



8100 SLAUSON AVE.
MONTEBELLO, CA 90640
(323) 728-2010

Fan Shaft Repair Same Day!

Repaired onsite at your location
within one day by methods of
thermal spray and grinding.

WORN BEARING AREA



SHAFT PREPARED



FINISH GRINDING



FINISH SIZE FOR BEARING



PowersBros.com

License 1021366

Powers Bros. On Site Fan Shaft Repair

Have you ever had a fan shaft with a worn bearing area, but the shaft was too large to remove?

Powers Bros has developed an on site process to repair the damaged bearing area while the shaft stays in the unit. The process includes metalizing (material build up) the damaged area and finish grinding to factory size.

What you get is a good surface finish and a harder surface ready for a bearing.

CALL TODAY FOR A FREE ESTIMATE!

METALLIZING



Powers Bros. can fabricate new shafts and stocks common sizes in Montebello, CA for next day shipments.

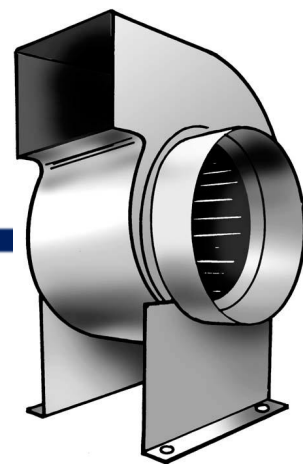

8100 SLAUSON AVE. MONTEBELLO, CA

(323) 728-2010

Sales@PowersBros.com

License # 1021366

Metallizing is a technique of coating metal on the surface of objects. Metallic coatings may be decorative, protective or functional. Techniques for metallizing fan shafts involves starting with a combustible gas, oxygen, compressed air and an alloy. The gas/oxygen mix melts the alloy and the compressed air combined with the metallizing gun sprays the molted alloy onto the object. Learn more about Thermal Spray at, PowersBros.com